

SECTION THRU "A-A"

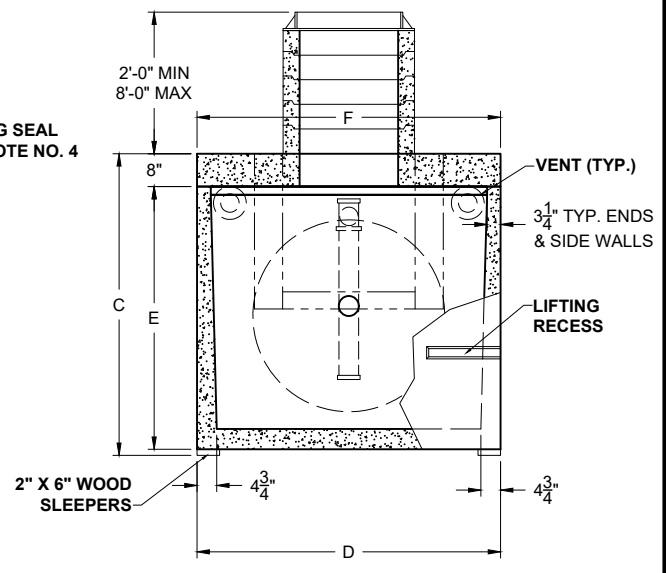

SECTION THRU "B-B"

ALL DIMENSIONS ARE IN INCHES & WEIGHTS IN LBS - (RISER WT. NOT INCLUDED)

EXCAVATION SPECIFICATIONS

MODEL	A	B	C	D	E	F	G	H	I	APPROX. WEIGHT	LENGTH	WIDTH	BELOW INLET	TANK HEIGHT
PC C-2-2000-HD	50	48	63	74	55	74	24 3/4	41 1/2	4 1/2	29,020	21'-0"	9'-2"	4'-2"	5'-5"
PC C-2-2500-HD	59	57	72	74	64	74	29 1/4	50 1/2	4 1/2	31,450	21'-0"	9'-2"	4'-11"	6'-2"
PC C-2-3000-HD	62 1/2	60 1/2	75 1/2	85	67 1/2	85	30 3/4	53 1/2	5	36,690	21'-0"	10'-1"	5'-2 1/2"	6'-5 1/2"

PRODUCT NAME:
CLARIFIER

DESCRIPTION:
 2000 THRU 3000 GALLONS
 H-20 TRAFFIC RATED

DESIGN SPECIFICATIONS
 DESIGN LOAD: H-20 TRAFFIC RATED

WITH DRY SOIL CONDITIONS (WATER LEVEL BELOW TANK), SUITABLE SUB-BASE BEDDED WITH GRANULAR MATERIAL SHALL BE PREPARED TO HANDLE ANTICIPATED LOADS. FOR COMPLETE DESIGN AND PRODUCT INFORMATION, PLEASE CONTACT PRO-CAST PRODUCTS.

PRO-CAST PRODUCTS RESERVES THE RIGHT TO MAKE CHANGES TO PRODUCT DESIGN AND/OR DIMENSIONS WITHOUT NOTICE. PLEASE CONTACT PRO-CAST PRODUCTS WHENEVER NECESSARY FOR CONFIRMATION OR ADVICE ON PRODUCT DESIGN.

- NOTES:
- (NOT USED)
 - REFER TO SPECIFICATION SHEET NOS. S-251 & S-252
 - REFER TO SPECIFICATION SHEET NO. S-201
 - REFER TO SPECIFICATION SHEET NO. S-250

SCALE: DO NOT SCALE
 DRAWN BY: TPC 12.20.2024
 REVISED BY:
 CHECKED BY:

DRAWING NO.
C-002